

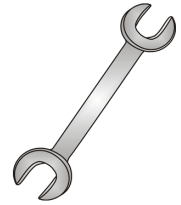

# Tow-Trust Towbars

Important: Please read General Notes overleaf before fitting



Issue 5

## TVW622 VOLKSWAGEN TOUAREG 2003> AUDI Q7 2006> PORSCHE CAYENNE 2002>

Item	Qty	Description	Item	Qty	Description
A	1	Crossmember	C	2	M16 x 50 Bolts & Nyloc Nuts
			J	8	M14 x 40 x 1.5 Bolts & S/P Washers
			K	8	M12 x 40 x 1.5 Bolts & S/P Washers
			L	8	14 x 27 Flat Washers
			M	8	12 x 25 Flat Washers

1. Remove rear bumper. Four fixings along the lower edge, four fixings in each wheel arch and two fixings under each light cluster. NOTE: Light clusters are not easily removed, to release, carefully pull light cluster rearwards. It is not recommended to use any form of tools to lever the light clusters out as they crack very easily. **(These are only a guide due to bumper variations between models).**
2. Remove the four original fixings securing the crash beam. (Hand beam and fixings back to the customer)
3. Using Item J with Item L or Item K with Item M bolt Item A to rear panel.
4. Fully tighten all bolts and ensure the Towbar is rigid and secure.
5. Cut a section from the lower edge of the bumper 70mm wide x 125mm deep. If required trim to suit, some vehicles may require a 190mm deep cut.
6. Refit bumper.
7. Using Item C bolt the ball bracket and wiring plate (not supplied in this kit) to the mounting plate.

**NOTE: Bumpers fitted with either OEM Tow flap or pre-cut hole DON'T require any additional bumper cut.**

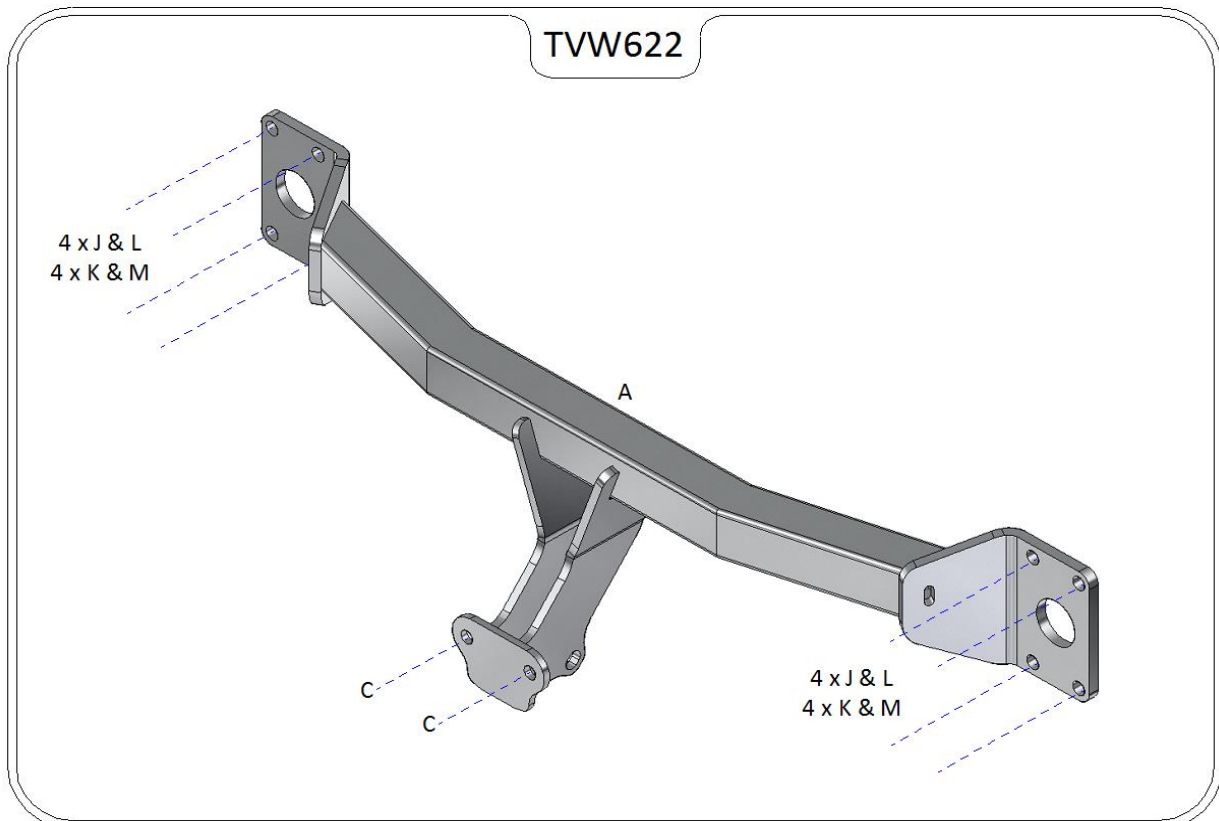

**Note:**

1. Recommended Torque Setting for M12 Grade 10.9 -139 Nm. (For other Torque Settings see notes overleaf.)
2. Nose load limits and vehicle manufacturers trailer / caravan weight limits must be observed.