



Tow-Trust Towbars

Important: Please read General Notes overleaf before fitting



Issue 14

TSDA2VK-6207 AUDI A3 SPORTBACK 2016> / AUDI Q2 2016> / AUDI A3 CABRIO 2017 / AUDI A3 SALOON 2016> / SEAT LEON 2017> / SKODA OCTAVIA 2013> / SKODA SUPERB 2015> / VOLKSWAGEN ARTEON 2017> / VOLKSWAGEN GOLF EST 2013> / VOLKSWAGEN GOLF ALLTRACK 2015> / VOLKSWAGEN PASSAT 2015> / SEAT LEON ST 2020> / VOLKSWAGEN GOLF 8 2020>

Item	Qty	Description	Item	Qty	Description
A	1	Crossmember	E	2	M12 x 25 Bolts & S/P Washers
B	1	N/S Side Arm	F	4	M10 x 35 Grade 10.9 Bolts & 4 S/P Washers
C	1	O/S Side Arm	G	4	M10 x 40 Grade 10.9 Bolts, 2 Nuts & 4 S/P Washers
D	1	6207 Detachable Neck	H	2	M12 x 22 Bolts & S/P Washers
			J	4	10 x 30 Flat Washers
			K	4	10 x 25 Flat Washers
			L	4	12 x 25 Flat Washers
			M	1	Flip Up Socket Plate (TTFP/LH)
			N	2	Handed Sensor Brackets
			P	2	M6 x 25 Bolts & Nyloc Nuts

BUMPER REMOVAL:

1. Remove the rear light clusters, SKODA: Two fixings found behind black plastic covers, AUDI/SKODA/SEAT/VW: One fixing inside boot.
2. AUDI/SKODA/SEAT/VW: Remove four fixings from each wheel arch. SEAT ONLY: Two fixings under light cluster each side, AUDI ONLY: One fixing under light cluster each side.
3. AUDI/SKODA/SEAT/VW: Remove four fixings along the lower edge, remove the plastic shut panel from inside the boot and remove four fixings through the rear panel. Carefully pull bumper tips from the vehicle then pull bumper rearwards.
4. VW PASSAT: Push plastic latches under light area to release the bumper.
5. Remove the rear impact beam and refit bolts into rear panel. (Beam is NOT refitted with the Towbar assembly).

TOWBAR INSTALLATION:

1. Locate the Towbar mounting points on the outside face of each chassis member, these are usually covered with tape.
2. Insert Item **B** and Item **C** into each correct chassis member and fix in place using Items **F** and Items **J**.
3. Using Items **G** with Items **K** fix Item **A** between each side arm. (Items **B** & **C**). **Note:** Use Item **N** & **P** to remount sensors if fitted.
4. Using Items **H** with items **L** and Items **E** with Items **L** fix Item **D** and Item **M** to Item **A**.
5. Fully tighten all fixings to the correct torque settings. **Golf 8:** Always lift the bar assembly as high as possible whilst torquing to ensure sufficient bumper clearance is achieved for the use of the detachable neck.
6. Most vehicles come with a pre-cut bumper but if not cut the bumper as illustrated and refit to the vehicle.

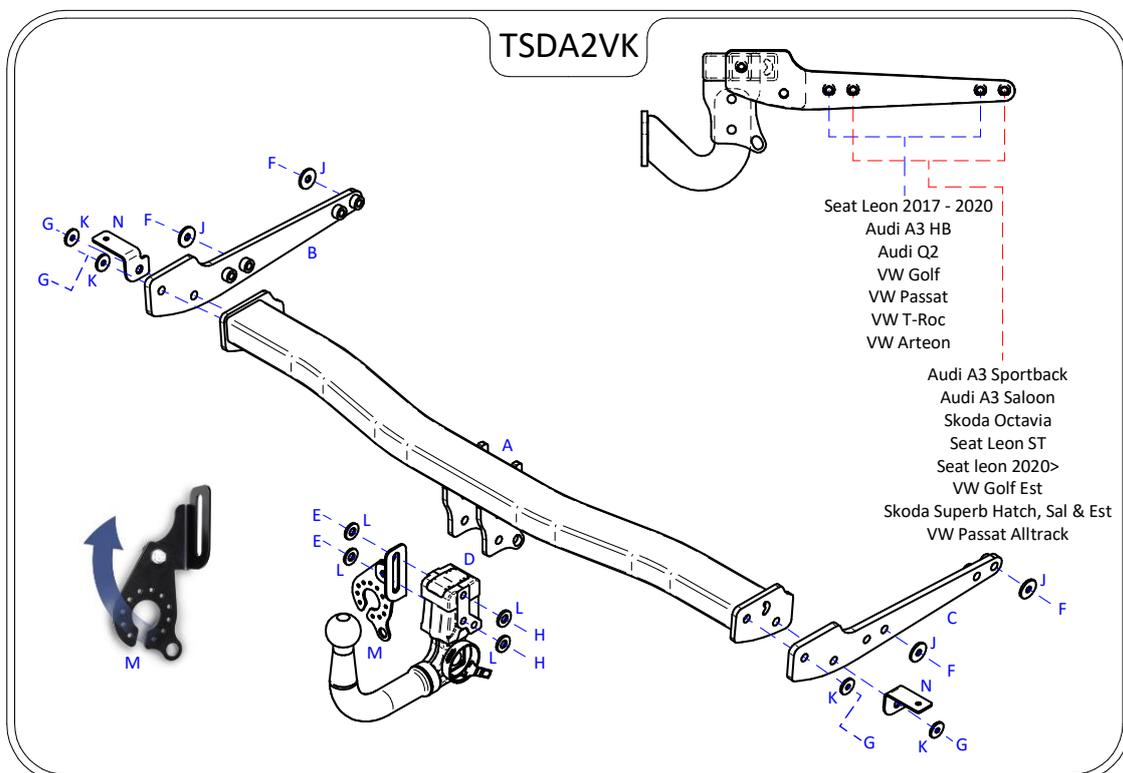

Note:

1. Recommended Torque Setting for M12 Grade 10.9 -130 Nm. (For other Torque Settings see notes overleaf.)
2. Nose load limits and vehicle manufacturers trailer / caravan weight limits must be observed.

TSDA2VK

PRE MARKED AREA
INSIDE BUMPER

AUDI A3 HATCH
AUDI A3 SALOON
AUDI A3 SPORTBACK

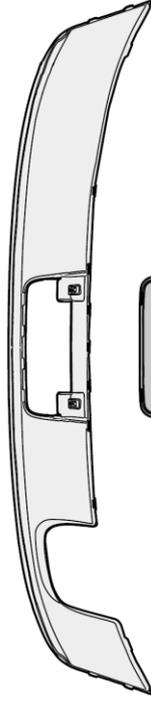
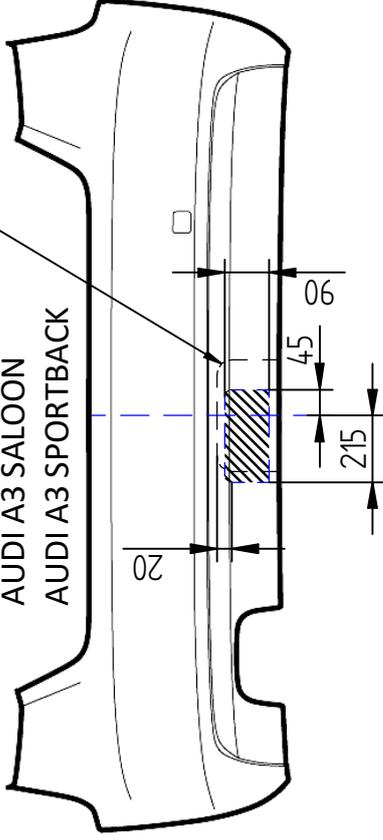

Or Fit Lower Towing
Diffuser With Tow Flap

SEAT LEON SC
SEAT LEON ST

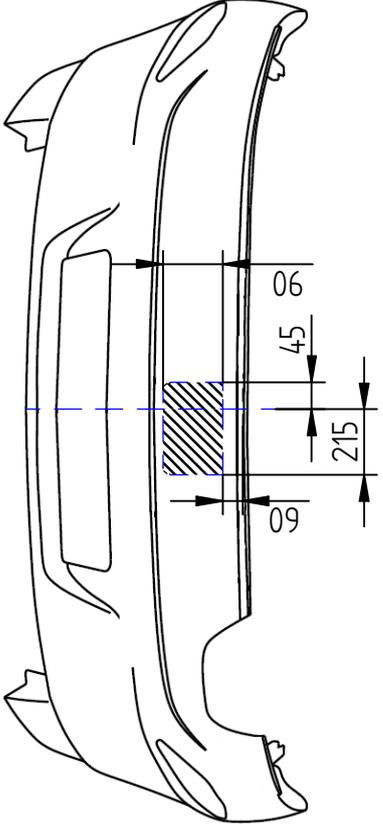

Or Cut Pre Marked Area
Inside Bumper & Fit Cover

SKODA OCTAVIA
VW GOLF EST.
VW PASSAT
VW ARTEON
SKODA SUPERB
T-ROC
AUDI Q2

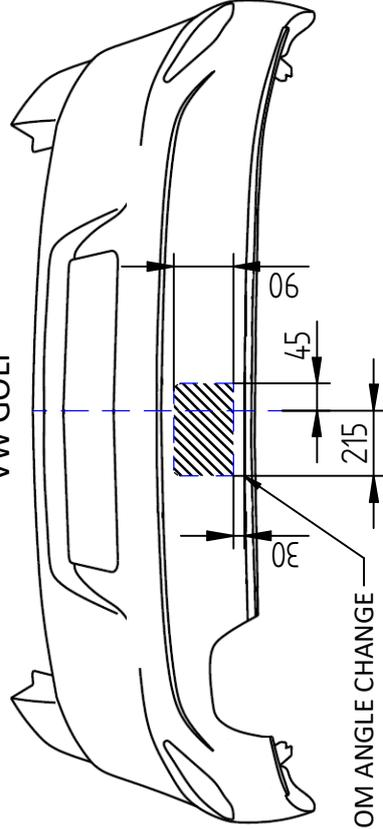

FROM ANGLE CHANGE

Or Cut Pre Marked Area
Inside Bumper & Fit Cover

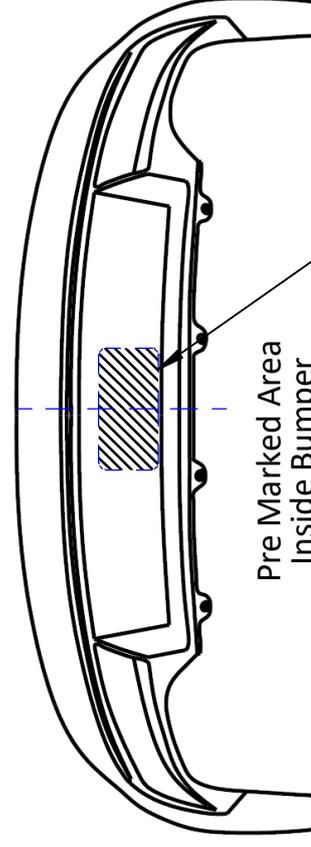

Pre Marked Area
Inside Bumper

Cut up to Edge

NOTE: Pre Marked Areas May Require
Additional Cuts For Flip Up Socket Plate