

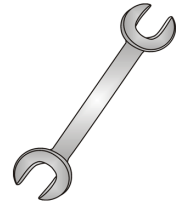

Tow-Trust Towbars

Important: Please read General Notes overleaf before fitting



Issue 2

THON5SN Honda Civic 3 & 5 Door Hatch 2012>

Item	Qty	Description	Item	Qty	Description
A	1	Crossmember	F	2	M12 x 110 Grade 10.9 Bolts & Nyloc Nuts
B	2	Handed Side Arms	G	4	M8 x 30 Bolts & S/P Washers
C	1	ACS1 / 9201 Swan Neck	H	8	M10 x 35 Bolts, 4 Nuts & 8 S/P Washers
D	2	40mm O/D Tube x 20mm Long	J	2	15mm Spacer Plates
E	6	40mm O/D x 1mm Shims	K	1	VASP8 L/H Socket Plate
X	2	M16 Black Bolt Caps	L	1	M16 x 110 Bolt & Nyloc Nut
			M	4	8 x 25 Flat Washers
			N	4	10 x 25 Flat Washers
			P	4	10 x 40 Flat Washers
			R	4	12 x 25 Flat Washers
			S	2	16 x 27 Flat Washers

BUMPER REMOVAL:

1. Remove mud flaps (if fitted) one fixing on outer edge, one fixing on inner edge and one fixing on the under section.
2. Remove the rear bumper, eight fixings along the lower edge, two fixings under plastic covers in boot opening. Remove wheel arch trims and remove the remaining two fixings. Pull out the bumper tips outward and slide bumper rearward.
3. Remove the impact beam (six fixings). Pull upwards to remove. (Impact Beam is not refitted with the Towbar)

TOWBAR INSTALLATION:

1. Using Item G with Item M loosely fit Item A to the rear panel.
2. Using Item L with Items S fix Item A to the Towing eye using Items D and Items E as spacers. (Please note sometimes the towing eye isn't central so use the necessary amount of Items E to centralise Item A).
3. Insert Items B through the Towbar end plates and the rear panel and fix to the vertical mounting points found on the lower face of each chassis member using Item H and Item P.
4. Using Items H with Items N fix Items B to Item A.
5. Using item F with item R and item J bolt item C to item A.
6. Fully tighten all fixings ensuring the Towbar is rigid, square, central and secure.
7. Cut the rear bumper as per the sketch below, cut the under tray up to the existing cut out and refit to the vehicle.

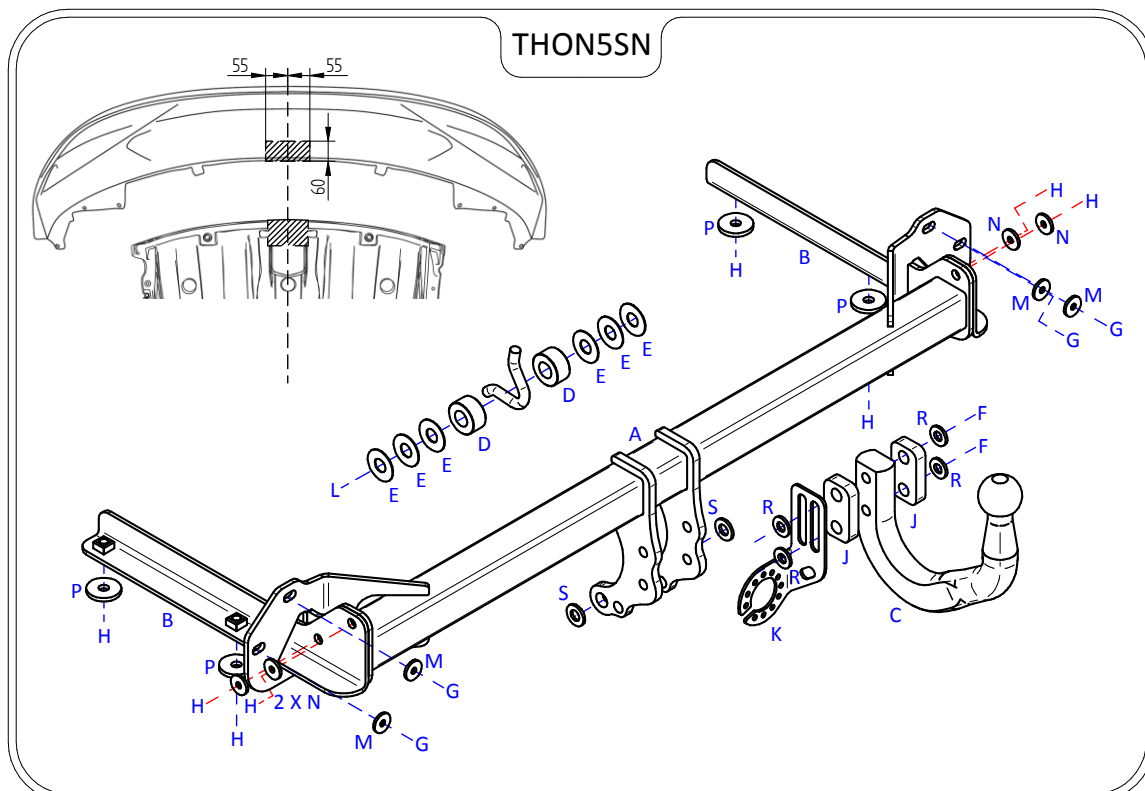

Note:

1. Recommended Torque Setting for M12 Grade 10.9 -139 Nm. (For other Torque Settings see notes overleaf.)
2. Nose load limits and vehicle manufacturers trailer / caravan weight limits must be observed.