

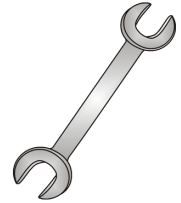

Tow-Trust Towbars

Important: Please read General Notes overleaf before fitting



Issue 3

TCV2VK CHEVROLET CAPTIVA 2006>

Item	Qty	Description	Item	Qty	Description
A	1	Crossmember	D	2	M12 x 25 Bolts & S/P Washers
B	2	Handed Side Arms	E	6	M12 x 55 Bolts & S/P Washers
C	1	Detachable Housing	F	6	M12 x 35 Bolts, 2 Nuts & 6 S/P Washers
			G	4	M6 x 40 Bolts, Nuts & S/P Washers
			H	2	M12 x 22 Bolts & S/P Washers
			J	8	12 x 40 Flat Washers
			K	8	12 x 25 Flat Washers
			L	4	6 x 20 Flat Washers
			M	1	Flip Up Socket Plate (TTFP/LH)
			N	4	17mm X 15mm Tubes (2013> ONLY)

BUMPER REMOVAL:

1. First remove two fixings from each rear light cluster and pull rearward to release, this will reveal one bumper fixing under each light, locate and remove.
2. Remove six fixings along the top edge and six fixings along the lower edge.
3. Remove three fixings around each wheel arch.

TOWBAR INSTALLATION:

1. Lower the spare wheel to gain access to all Towbar mounting points.
2. Remove the rear crash beam from the rear panel and towing eye nearside chassis member. (Crash beam and towing eye are not refitted with Towbar assembly)
3. Using Item E with Item J loosely bolt Items B to the inside face of each correct chassis member.
4. Using Item F with Item J loosely bolt Items B to the vertical mounting point in each chassis member.
5. Using Item F with Item K bolt Item A between each side arm.
6. Using Item D with Item K and item H with Item K bolt Item C and Item M to Item A.
7. Fully tighten all nuts and bolts ensuring Towbar is rigid square and secure.
8. Cut bumper as shown in sketch (2007 - 2013 ONLY) and refit using Item G and Item L on the bumper tabs (Use Item M on 2013> Vehicles ONLY).

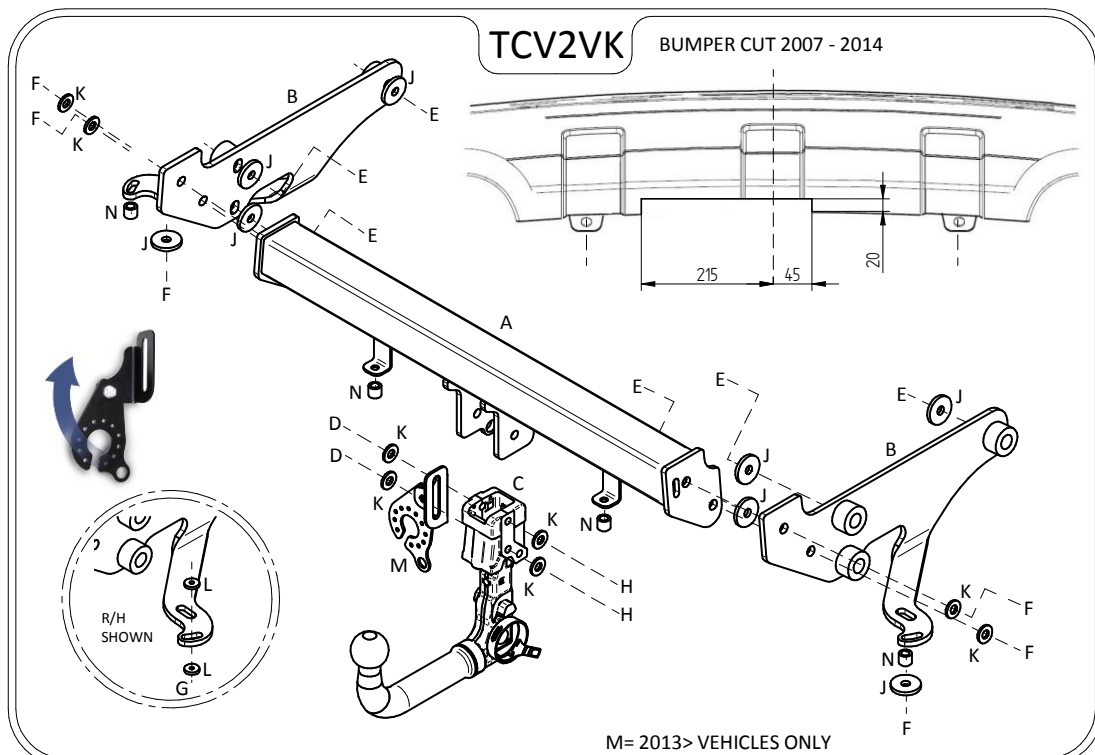

Note:

1. Recommended Torque Setting for M12 Grade 10.9 -139 Nm. (For other Torque Settings see notes overleaf.)
2. Nose load limits and vehicle manufacturers trailer / caravan weight limits must be observed.