



TBMW11VK BMW 1 Series 2011>, 2 Series Inc Active & Grand Tourer & GT & Grand Coupe 2014>, 3 & 4 Series 2012-2020 Inc GT, M-Sport, Gran Coupe & Cabriolet, X1 2016>, X2 2017>, Mini Clubman 2015>, Mini Countryman 2016>

Item	Qty	Description	Item	Qty	Description
A	1	TBMW11 Crossbar	E	1	TTFP/RH Flip Up Socket Plate
B1	1	Side Arm 1	F	2	M12 x 25 Bolts & S/P Washers
B2	1	Side Arm 2	G	2	M12 x 25 Bolts & S/P Washers
C	2	Inner Panel Bracket	H	2	M6 x 20 Self Tapping Bolts
D	1	6201 Detachable Neck	J	4	M12 x 35 Flange Bolts
OE1	4	Original BMW Crash Beam Fixings (115 Nm)	K	2	6 x 15 Flat Washers
OE2	2	Original Inner Bumper Panel Clips	L	4	12 x 25 Flat Washers
			M	4	12 x 40 Flat Washers
			N	8	Large Plastic Rivets (X1 Only)

Bumper Removal:

1. Remove the rear light clusters and any fixings revealed once they are off the vehicle from each side.
2. Remove the fixings from inside the wheel arch and any tip screws from each side.
Note: Some vehicles may have wheel arch trim that also requires unclipping to access the fixings located behind them.
3. Remove the fixings from the lower bumper edge then pull bumper out sideways and rearwards to remove, carefully unplugging any wiring looms that may be attached.
4. Remove the rear crash beam, once removed unclip any inner bumper panels fixed to it.
Note: The crash beam will not be refitted with the towbar however, the inner bumper panel will be fixed to the towbar. Retain the gaskets for fitting the side arms.

Towbar Installation

Note: All the fixing images are contained in Figure 1 apart from the fixings for the chosen neck which are in Figure 5.

1. Using Figure 1, loosely fix items **B1** and **B2** to the rear panel using items **OE1** with items **M**.
2. Using Figure 2, loosely fix item **A** to items **B1** and **B2** using items **J**.
3. Fully tighten all the fixings ensuring the towbar is rigid, square, and secure.
4. Using Figure 3, loosely fix items **C** to item **A** using items **H** with items **K** then fix the inner bumper panel to items **C** using items **X2**, centralise the panel and fully tighten the fixings. (1 Series 2011-2019 and 2 Series 2014-2021) Fix the height shield to item **A** as shown using item **H** with items **K**.
5. Using Figure 4, fix item **D** with item **E** to item **A** using items **F** with items **L** and items **G** with items **L** and fully tighten.
6. Cut either the bumper, lower panel or heat shield as required. **Note:** Most bumpers have a pre-cut bumper and are a direct fit, others remove the pre-marked area. Some heat shields the middles of the crossbar will require a mousehole style cut, others will be in the ground facing section. Be careful of making sharp edges of this style, we would recommend some trim or rolling the edges over. (The minimum cut width is 70 mm from the centreline towards the nearside with 280 mm Overall Width).
7. Remount the rear bumper and fixings.

Figure 1

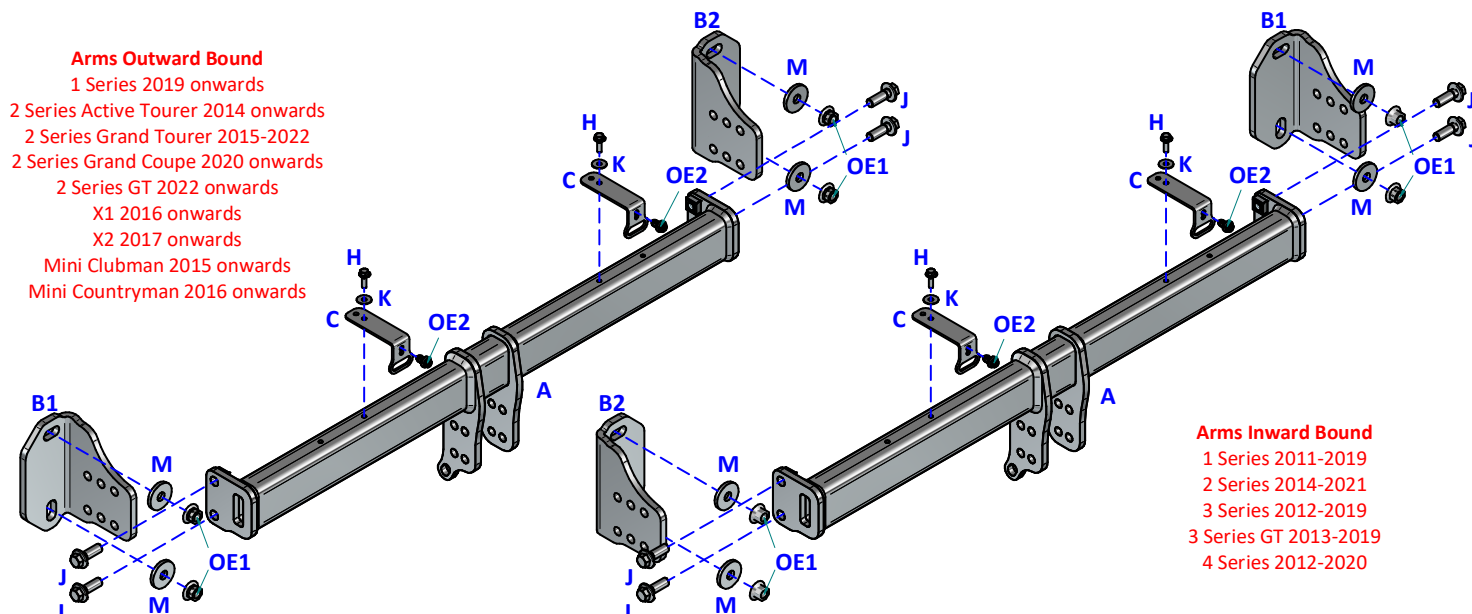
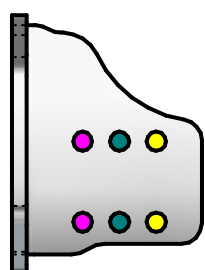

Figure 2



- 1 Series 2011-2019
- 2 Series 2014-2021
- 3 Series 2012-2019
- 4 Series 2013-2020
- X1 2016-2022

- 2 Series Grand Tourer 2015-2022
- 2 Series Active Tourer 2014 onwards
- X1 2022 onwards
- X2 2017 onwards
- Mini Clubman 2015 onwards
- Mini Countryman 2016 onwards

- 1 Series 2019 onwards
- 2 Series Grand Coupe 2020 onwards
- 2 Series GT 2022 onwards
- 3 Series GT 2014-2020

Figure 3

Front View

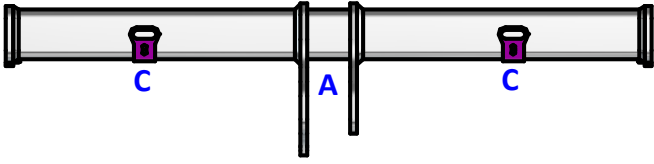

Position Of Bracket C
Inner Bumper Support Mounting
3 Series GT 2014-2020

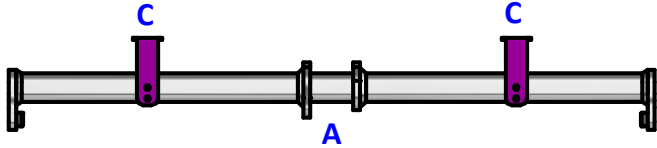

Bottom View

Front View

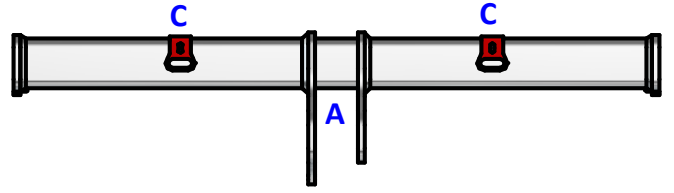

Position Of Bracket C
Inner Bumper Support Mounting
3 Series 2012-2019
4 Series 2013-2020

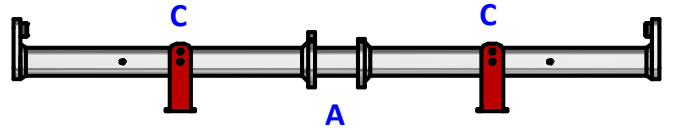

Top View

Top View

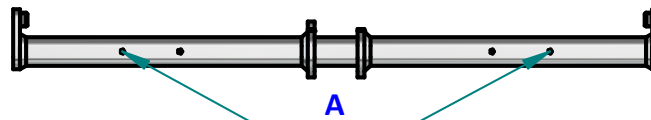

Attach The Heat Shield To The
Top Of The Crossbar
1 Series 2011-2019
2 Series 2014-2021

Figure 4

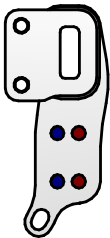

- 1 Series 2011 onwards
2 Series 2014-2021
2 Series Grand Tourer 2015-2022
2 Series Active Tourer 2014 onwards
3 Series 2012-2019
4 Series 2012-2020
X1 2016-2022
Mini Clubman 2016 onwards
Mini Countryman 2018 Onwards
- 2 Series GT 2022 onwards
3 Series GT 2014-2020
X1 2023 onwards
X2 2018 onwards

Figure 5

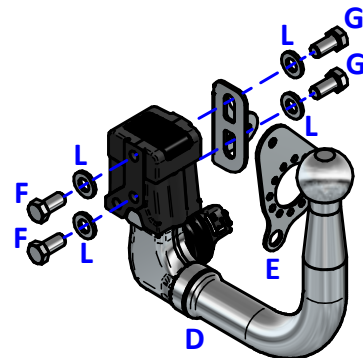

Notes:

1. For Torque settings see general notes overleaf.
2. Nose load limits and vehicle manufacturer's trailer / caravan weight limits must be observed.
3. We recommend the use of PRO-TOW Couplings with all our products.