



ISO9001 FM38198

FITTING INSTRUCTION

PG4414 Batch 000000	Peugeot Boxer, Citroen Relay/Jumper, Fiat Ducato (Chassis Based Vehicles)(From 2006) Type Approval Number E11*55R01/06*11589*00
-------------------------------	---

COMPONENTS		
ITEM	QTY	DESCRIPTION
A	1	Towbar
C	1	Side Arm (L/H - With Slot)
D	1	Side Arm (R/H - Without Slot)
E	2	Cleat
F	2	Chassis Insert with Captive Nut
CP	1	10mm Coupling Packer (ZMCP10)

BOLT PACK		
ITEM	QTY	DESCRIPTION
G	2	M16 x 55 Bolts, Nuts & Washers
H	2	M12 x 140 Bolts & Nyloc Nuts
I	4	M12 x 35 Bolts & Nyloc Nuts
J	2	M12 x 35 Bolts & Washers
K	6	M10 x 40 Bolts, Nuts & Washers
L	4	M12 H/D Washer – 30mm O/D x 5mm Thick
M	10	M12 Flat Washer – 23mm O/D x 1.6mm Thick
N	10	M10 H/D Washer – 30mm O/D x 5mm Thick
X	2	Spacer Tubes – 19mm O/D x 74mm Long

FITTING PROCEDURE

- ⇒ Locate & remove the square rubber plug from the underside of each chassis rail & insert chassis inserts (F) into the hole. It is important that the threaded end is inserted first and then drawn back to allow the thread to locate central to the square hole. Loosely attach cleats (E) using bolts (J), with 1x M12 flat washer (M) under the bolt head and 2x M12 flat washers (M) inside each square pressing.
- ⇒ Locate the 6x existing holes in the vehicle's rear panel (3x surrounding each chassis rail). Loosely attach towbar (A) using bolts (K) with heavy duty washers (N) under the bolt heads, and also forward of the panel where not in contact with cleats (E). **Note:** On occasion there may be a small amount of panel misalignment and it may be necessary to open up holes (K). **Note:** Ensure any adjacent wiring harnesses do not get trapped.
- ⇒ On SWB-MWB-LWB models: Locate existing mounting positions (H). Loosely attach side arms (C) & (D) using bolts (H) with heavy duty washers (L) under both the bolt heads & on the outside of the chassis. Attach side arms (C) & (D) to towbar (A) (Ensure correct positioning) using bolts (I) with flat washers (M) as illustrated.
- ⇒ On Maxi / XL models: Lower spare wheel. Loosely attach side arms (C) & (D) to towbar (A) (Ensure correct positioning) using bolts (I). Locate side arms (C) & (D) against side of chassis & ensuring assembly is level and square, mark and drill at 13mm O/D through each chassis rail for positions (H). **Note:** For reference, the hole centre should be 82mm from the base of the chassis rail. Remove side arms (C) & (D) and open up the position on the outside face only to just accept spacer tubes (X). Loosely attach side arms (C) & (D) using bolts (H) with heavy duty washers (L) under both the bolt heads & on the outside of the chassis, and spacer tubes (X) inside the chassis. Attach side arms (C) & (D) to towbar (A) (Ensure correct positioning) using bolts (I) with flat washers (M) as illustrated.
- ⇒ Ensuring assembly is square & level, tighten all bolts starting with (K). Raise spare wheel.
- ⇒ **Note:** Use coupling packer (CP) when attaching a standard 50mm ball coupling to the lower hole setting.

NOTE: When fitting to vehicles with a Tipper body always ensure sufficient clearance is provided between the drop down tailboard and the coupling during all stages of raising the body. It is recommended to install guides to prevent the tailboard from jamming on the towbar coupling. Failure to do so may result in the tailboard being crushed, possibly causing significant damage to the body. Please refer to information provided in the tipper conversion operator's manual.

A type approved towball with 'D' and 'S' values that match or exceed those of the towbar must be fitted. The horizontal distance from the towbar faceplate to the centre of the ball must not exceed 120mm. The vertical distance from the centre of the towball holes to the centre of the ball must not exceed 75mm. The towbar has also been tested for use with PCT Automotive universal coupling ZC1405, Bradley universal coupling part code V352L (E40TC) or Dixon-Bate universal coupling part code 202014.

TIGHTEN ALL BOLTS

TORQUE SETTINGS ISO Coarse Pitch M8=29Nm, M10=58Nm, M12=102Nm, M16=252Nm
ISO Fine Pitch M8=31Nm, M10=61Nm, M12=111Nm

THE VEHICLE MANUFACTURER'S SPECIFICATION FOR THE TRAILER WEIGHT AND NOSE LOAD LIMITS MUST BE OBSERVED.

FITTING DIAGRAM

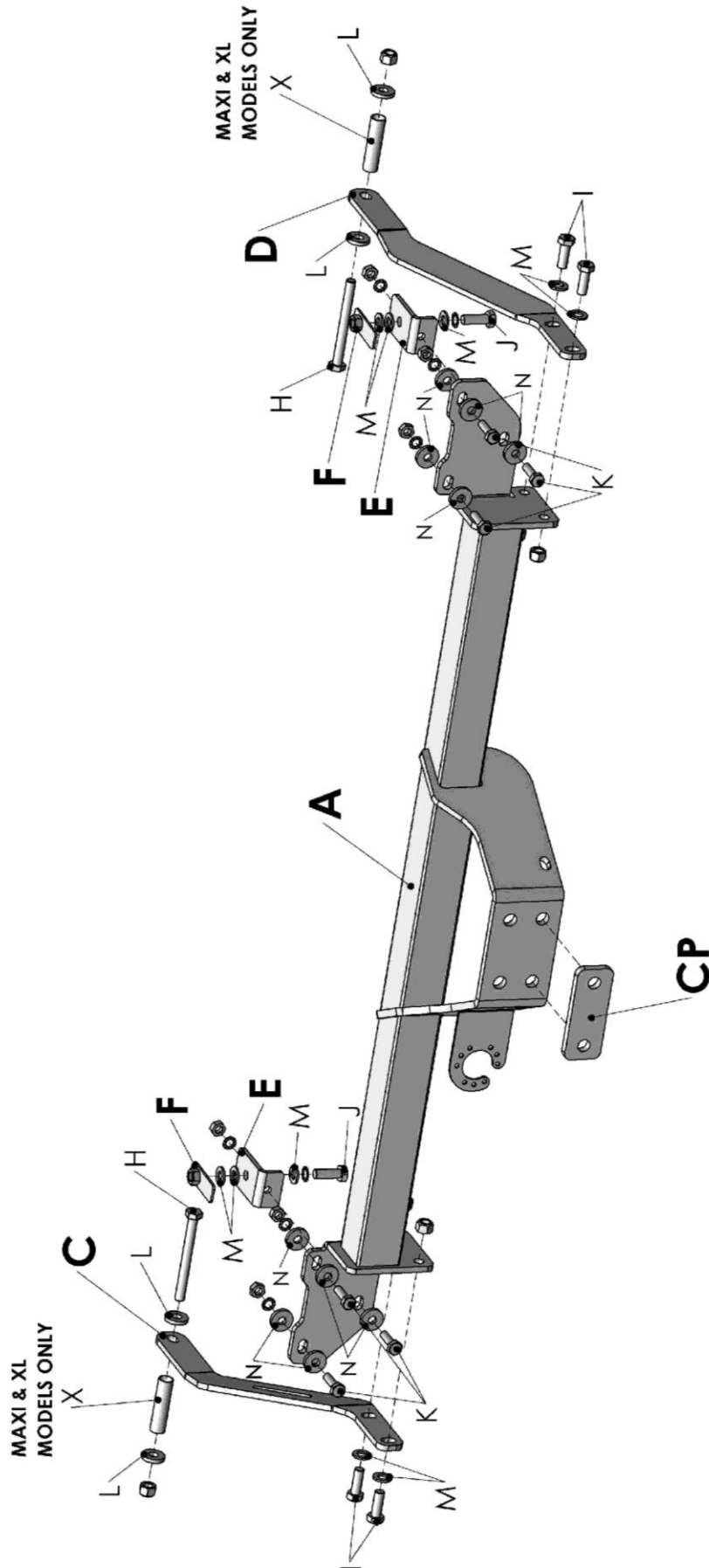

IMPORTANT PRODUCT INFORMATION & GUARANTEE

(TO BE RETAINED WITH THE VEHICLE AND PASSED TO SUBSEQUENT OWNERS)

Thank you for purchasing a PCT Automotive product. Please read the following information carefully before fitting or using your PCT Automotive product.

GUARANTEE

We shall free of charge either repair or at our option replace defective goods where the defects appear

- i. if the goods are a towbar manufactured by us, during the economic lifetime of the vehicle it was first fitted to
- ii. in the case of all other products manufactured by us, within 3 years following the date of your order

PROVIDED THAT (in each case) such defects shall be found to our reasonable satisfaction to have arisen substantially from our faulty design, workmanship or materials and have not arisen by reason of a failure to follow our instructions (whether written or oral), any modification, misuse, neglect or interference with the installation, any damage or abuse to the goods or vehicle by impact or vandalism or by a failure to carry out reasonable inspection, maintenance and/or adjustment.

At all times, the above guarantee is subject to our standard terms and conditions of sale a copy of which is available upon request from our offices.

TOWING LIMITS

Our towbars have been designed for towing up to the vehicle manufacturer's maximum recommended trailer weight and nose load limits for your model. Towing with gross weights above that recommended at any time will invalidate the guarantee and cancel any liability for damage. Towing a twin axle trailer, towing over rough ground or using a bicycle/motorcycle carrier, etc, exerts extreme loads on to a towbar and extra care should be taken in these situations not to exceed the vehicle manufacturer's maximum recommended limits.

PRODUCT IDENTIFICATION MARK

Your product carries a product identification mark. This mark carries important product and batch code information and if the product is type approved it also carries the type approval details which are required by law. Under no circumstances should this mark be defaced, removed or damaged.

INSTALLATION, INSPECTION, MAINTENANCE AND ADJUSTMENT

GENERAL INSTALLATION

- ⇒ All products should only be fitted by competent persons. Electrical products must only be fitted by an experienced auto-electrician.
- ⇒ Read the product fitting instructions carefully and check all components are included in the fitting kit before commencing installation.
- ⇒ Check vehicle for corrosion and/or accident damage. Towbars should not be fitted to any vehicle suffering from corrosion or accident damage or which is not in a roadworthy condition.
- ⇒ Clean off all road dirt, underseal and sound deadening mastic where parts are to fit to ensure correct seating of all components.
- ⇒ Bumper cut information is given as a guide only. Variations in models may occur therefore the fitter should always check that the bumper cut is necessary and of the correct size and shape before commencing with the cut.
- ⇒ All drilling swarf should be removed from the vehicle and all holes drilled in the vehicle should be treated with an appropriate rust inhibitor.
- ⇒ Do not fully tighten bolts before towbar is completely fitted unless instructed to do so in the fitting instruction, this will allow some variances to be overcome before final tightening of bolts.

PAINT & CORROSION

Towbars manufactured by PCT Automotive undergo a phosphate chemical pre-treatment prior to a polyester powder coat finish being applied. For long lasting good looks and in order to prevent corrosion the towbar should be regularly inspected for paint damage and wherever necessary re-painted in an appropriate finishing paint or underseal. The vehicle should also be regularly checked for any corrosion that could affect the towbar installation. Towbars should not be used on any vehicle suffering from corrosion that could affect the towbar installation.

BOLTS

All towbar fixing bolts should be checked initially after the first 300 towing miles, or the initial 500 miles of driving uncoupled, and then every 3,000 towing miles or to coincide with the vehicle manufacturer's recommended service intervals, whichever is the sooner. All towbar fixing bolts should be tightened using an appropriate torque wrench to the settings specified in the towbar fitting instruction.

ELECTRICAL INSTALLATION, TEST/COMMISSIONING AND MAINTENANCE

Failure to comply with the following instructions may cause damage to the towing vehicle's wiring loom and/or towing electrics installation.

Where displacement tap connectors e.g. Scotchlocks, are the preferred method of connection, always use the correct colour coded tap connector for the size of cable to which it is to be connected. All towing relays and modules manufactured by PCT Automotive have cabling with a copper cross-sectional area in the range 0.5mm² to 1mm².

After installation of the 12N/12S sockets, prior to testing, a water displacement agent e.g. WD40 should be applied into the rear connection void through the water drain hole at the bottom of the sockets and also into the front pins under the socket flap. This socket maintenance should be carried out at least twice a year in the spring and autumn.

The towing electrics test procedure must be undertaken with the engine running. If any of the towing relays fail to function correctly, with the engine running and no other vehicle electrical systems turned on, check that the voltage across the vehicle's battery is between 13V and 14V approx, if this voltage is not correct, check the condition of the vehicle's battery/alternator.

Always ensure that the trailer/caravan/lighting board's own electrical systems are installed and functioning correctly before coupling to the vehicle's 12N/12S sockets.

Every six months (spring and autumn recommended) the battery and alternator of the vehicle should be checked to determine correct electrical functioning. All connections of the electrical installation including the earth should be checked for mechanical soundness and electrical quality. Plugs, sockets, relays and fixings should be checked for water ingress, mechanical soundness, electrical quality and general wear and tear.

Please complete the following information to validate the guarantee and for future reference.

VEHICLE OWNER NAME & ADDRESS:

VEHICLE MAKE & MODEL:

VEHICLE REGISTRATION NUMBER:

FITTER NAME & ADDRESS:

DATE TOWBAR FITTED:

If you have any comments or suggestions about the PCT Automotive product fitted to your vehicle, please address them to PCT Automotive, New Street, Holbrook Industrial Estate, Sheffield S20 3GH or email techsupport@pctautomotive.com
Your comments will help us in our aim to continually upgrade our products to meet the high standards expected by our customers.